

2012 National Robotics Competition - GEN II Football (Zone Competition)

General guidelines

1. A school team should comprise of 2 or 3 students and 1 school teacher.
2. All rules and regulations are subject to change without any prior notice.







Age Group Definition

1. Birthday falls in the period January 01, 1993 to December 31, 1999.

Regulations on materials used:

1. Except for special designations in competition rules, materials used by the teams to assemble their robots must be from 9797 LEGO® MINDSTORMS™ Education Base Set, 9695 MINDSTORMS™ Education Resource Set, 9648 Education Resource Set, and HiTechnic (HiTechnic NXT IRSeeker V2 sensor and HiTechnic NXT Compass sensor). The shapes and the colors must be exactly the same.
2. The control program must be written using the ROBOLAB or LEGO® MINDSTORMS™ Education NXT software. Teams that use materials and control programs that are not certified by the tournament will be disqualified from the competition.
3. Teams should prepare and bring all the equipment (software, portable computers, batteries, extension wires, etc.) that they need during the tournament. Teams should not use any flammable materials as part of their designs.
4. Teams should bring enough spare parts. In the event of accidents or equipment malfunction, the organisers are not responsible for any maintenance and replacement of equipment. Mentors are not allowed to enter the quarantine area to give instructions or guidance to their teams.
5. Batteries used during the competition can be 6 pieces of AA batteries or lithium batteries of LEGO® MINDSTORMS™ NXT. Other power supply devices which are not authorised by the organisers are not allowed to be used.
6. Teams are allowed to pre-fix and pre-program the robot or store the program in the laptop before the competition.
7. Modification of any original parts, for example, NXT Intelligent Brick, motors, sensors, etc. is not allowed. Violation of this rule will result in disqualification.

Eligible Motors and Sensors for the GEN II Football category:

Code	Product Picture	Product Name
9842		Interactive Servo Motor
9843		Touch Sensor
9844		Light Sensor
9846		Ultrasonic Sensor
NSK 1042		Hi-Technic IR Seeker
NMC 1034		Hi-Technic Magnetic Compass Sensor

Rules and Regulations

1. Playing Field

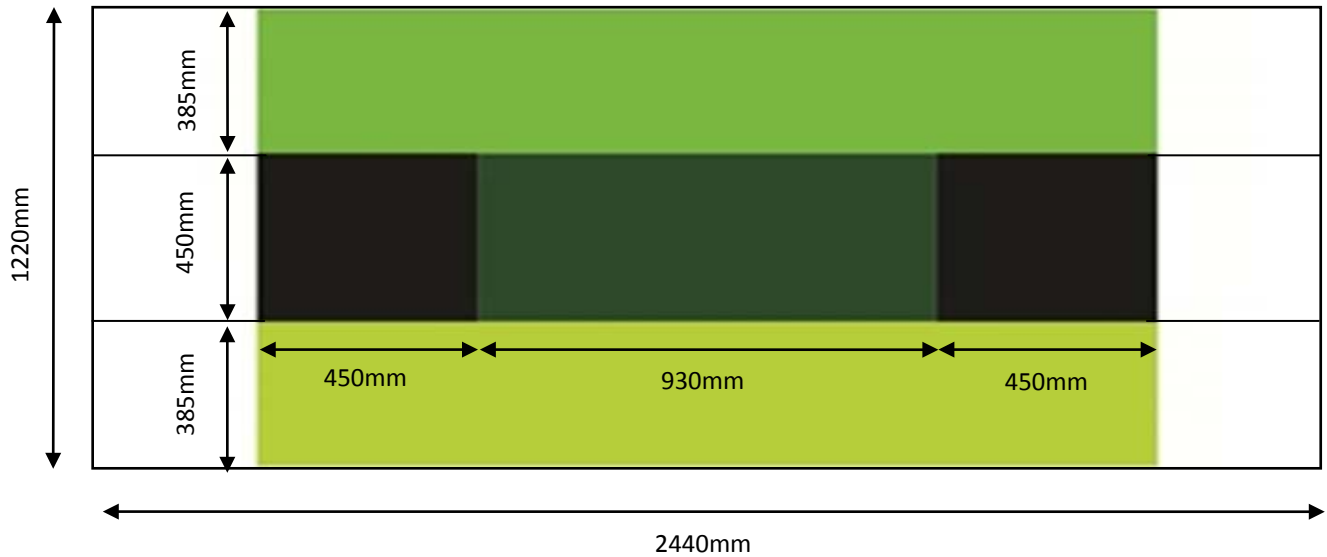

<error tolerance of court: $\pm 50\text{mm}$ >

1.1. Floor

- 1.1.1. The playing field is 122 cm by 244 cm.
- 1.1.2. The field may be placed on a table.

1.2. Walls

- 1.2.1. Walls are placed all around the field, including behind the goals.
- 1.2.2. The walls can be constructed of any material as they are not essential to game play.

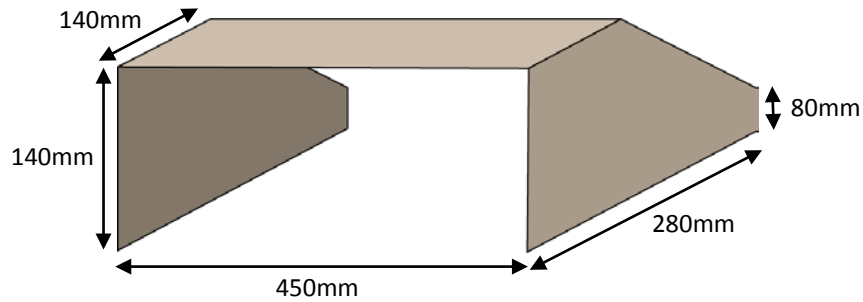

1.3. Goals

- 1.3.1. The width of each goal is 45 cm.
- 1.3.2. The surface within the goal area is flat and level (horizontal).
- 1.3.3. The side walls of the goals extend to the end wall to prevent ball from rolling behind the goals.

1.4. Neutral Zones

- 1.4.1. There are two neutral zones, shown in white below, defined in the field.
- 1.4.2. They are defined as the line between the corners of the penalty boxes, running along the field on the boundaries of the green colour zones.

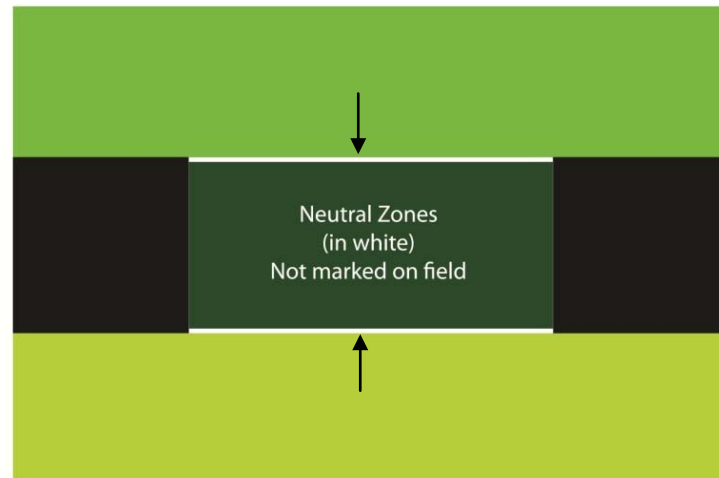

1.5. Lighting and Magnetic Conditions

- 1.5.1. Teams must come prepared to calibrate their robots based on the lighting and magnetic conditions at the venue. Every effort will be made by organizers to keep light levels as low as possible and locate soccer fields away from magnetic fields such as under floor wiring and metallic objects. However sometimes this cannot be avoided.

2. Ball

2.1. Specification

- 2.1.1. A well-balanced electronic ball diameter 7.5cm shall be used.
- 2.1.2. The ball will be used in the following modes:
 - Hitechnic Infrared Electronic Ball(IRB 1005) in MODE D (1200Hz pulsed)

3. Robots

3.1. Dimensions

- 3.1.1. Robots will be measured in an upright position and with all parts fully extended.
- 3.1.2. The upright robot must fit inside an upright 22cm diameter cylinder.
- 3.1.3. The robot height must be less than 22cm.
- 3.1.4. The robot weight must be not more than 1kg.
- 3.1.5. While being inspected, each robot must be upright and at its maximum size; i.e., anything that protrudes from the robot must be fully extended. If a robot has a moving part that extends in two directions, it will need to be inspected with this part operating. The robot must be able to operate without touching the measuring cylinder.

3.2. Control

- 3.2.1. Robots must be controlled autonomously.
- 3.2.2. Robots must be able to be started manually.
- 3.2.3. The use of remote of control any kind is not allowed.
- 3.2.4. Robots must be able to move in all directions.
- 3.2.5. Blue tooth communication between robots is acceptable as long as it does not interfere with the performance of other robots.

3.3. Marking/Colouring

- 3.3.1. Competitors must mark or decorate their robots to identify them as belonging to the same team. These must not influence game play and will not be considered in the size restrictions.
- 3.3.2. Colours of robots and/or light transmitters must not interfere with the sensor readings of other robots.

3.4. Teams and Tournaments

- 3.4.1. All teams shall consist of no more than 2 robots. Any substitution of extra robots during a tournament is forbidden and disqualification will result.

3.5. Construction

- 3.5.1. For the design of the robot, the following applies:
 - The following combinations of motors and sensors are allowable for NXT user:
 - NXT Controller = 1 unit
 - Motors = 3 units
 - Touch sensors = 2 units
 - Light sensors = 2 units
 - Lamp = 1 unit
 - Ultrasonic sensor = 1 unit
 - HiTechnic Compass sensor = 1 unit
 - HiTechnic NXT IR seeker sensor Version 2 = 1 unit
- 3.5.2. Robots must have a handle for referees to easily pick them up. The handle will not be included in above measurements.

3.6. Ball Capturing Zones and Movement

- 3.6.1. Ball Capturing Zones are defined as any internal space created when a straight edge is placed on the protruding points of a robot.
- 3.6.2. The ball cannot penetrate the Ball Capturing Zone by more than 3cm.
- 3.6.3. A robot cannot "hold" a ball.
Hint: Holding a ball means, taking a full control of the ball by removing all of its degrees of freedom. Example, this would mean fixing a ball to the robot's body, surrounding a ball using the robot's body to prevent access by others, encircling the ball or somehow trapping the ball with any part of the robot's body. If a ball stops rolling while a robot is moving, or a ball does not rebound when rolled into a robot, it is a good indication that the ball is trapped.
- 3.6.4. The ball cannot be held underneath a robot.
- 3.6.5. The ball must be visible and other players must be able to access the ball at all times.
- 3.6.6. The only exception to rule (3.6.3) is the use of a rotating drum that imparts dynamic back spin on the ball to keep the ball on its surface. This is called a "dribbler".
- 3.6.7. A dribbler must comply with Rule (3.6.2). The 3cm is measured from the contact point of the dribbler on the ball.

3.7. Goalies

- 3.7.1. If a goalie is used, it cannot limit its movement to a single direction on the field. It must be programmed to move in all directions.
- 3.7.2. The goalie must respond to the ball in a forward direction in an attempt to intercept the ball ahead of the goal. If required, its movement should be able to take some part of the robot outside of the penalty box (45 cm from goal).
Hint: The goalie cannot respond sideways and followed by a forward movement.
- 3.7.3. Failure to respond to the ball with forward movement down the field will result in the robot being classified as "Damaged." (Section 4.7.)

3.8. Kickers, Batteries and Robot Power

- 3.8.1. If a robot damages a ball or the field, it will be removed from play and receive a time penalty as damaged robots. A yellow warning sticker will be placed on the robot/s and the referee will record the infringement on the score card.
- 3.8.2. In the event of two colliding robots damaging a ball, both robots will be removed and given a yellow sticker. If the referee considers one robot to be significantly more aggressive than the other, they can choose to remove that robot from play.
- 3.8.3. Adjustments must be made to the robot/s to prevent this from re-occurring.
- 3.8.4. If a robot infringes again during the tournament, it will be disqualified from the tournament. *(If a robot has the power to damage an officially accepted NRC ball (See 3.2.1 and 3.2.2), it is a strong indication that the robot has been built with excessive power and the intention to damage other robots. The robot has not been built with the ideals of NRC and fair competition in mind, so the tournament committee has every right to remove that robot from the competition.)*

4. Game Play

4.1. Pre-game setup

- 4.1.1. Organizers will provide access to the competition area for calibration and testing prior to the competition and according to a schedule that will be made available at the start of the event.
- 4.1.2. Organizers will make every effort to allow at least 5 minutes of setup time before each game.
- 4.1.3. The ball will be checked for any damage by the referee before each half of the game is started.
- 4.1.4. This time is also for teams to express any concerns about the legality of opposing robots.

4.2. Length of Game

- 4.2.1. The game will consist of two 10-minute halves.
- 4.2.2. There will be a 3-minute break in between the halves.
- 4.2.3. The game clock will run for the duration of the game (two 10-minute halves), without stopping (except as noted in Referees Time Out in Section 4.9.4).
- 4.2.4. Teams can be penalized one goal per minute at the referee's discretion if they are late.
- 4.2.5. If a team does not report within 5 minutes of the game start, it will forfeit the game and the winning team awarded a 5-0 score line.

4.3. Start of Game

- 4.3.1. At the start of the first half of the game, the referee will toss a coin and the team first mentioned in the draw shall call the coin.
- 4.3.2. The winner of the toss can choose either (a) which end to kick to, or (b) to kick off first.
- 4.3.3. The loser of the toss will decide the other option.
- 4.3.4. The team not kicking off in the first half of the game will kick off to begin the second half.

4.4. Kick-Offs

- 4.4.1. Each half of the game begins with a kick-off.
- 4.4.2. All robots must be in located on their defensive side of the field.
- 4.4.3. Robots must not be running.
- 4.4.4. The ball is positioned by the referee in the centre of the field.
- 4.4.5. The team kicking off places their robots on the field first. Robots cannot be moved once they have been placed.
- 4.4.6. All robots on the team not kicking off must have some part of the robot in the penalty box.
- 4.4.7. On the referee's command, all robots will be started immediately by human team members.
- 4.4.8. The robot kicking off must make a clear strike of the ball and it must roll clear the robot by at least 5 cm. A robot that does not have a kicker must visibly release the ball to a distance of 5cm and not continue to push the ball. An illegal kick off will result in the opposing side being granted the kick off.
- 4.4.9. Any robots that are started before the referee's command will be removed from the field for one minute.

4.5. Scoring

- 4.5.1. A goal is scored when the whole of the ball crosses the goal line.

- 4.5.2. The ball must be free rolling to score a goal, otherwise it will be deemed "pushed" by the referee and disallowed. In the event of a pushed goal, play will not be stopped. The goal will not be allowed. The ball is placed on the nearest available neutral zone and play is continued. The robot must make a visible effort to kick or release the ball otherwise a goal will be deemed a "push". If no attempt is made to release the ball and it momentarily rolls free while in the control of a robot travelling towards goal, it will still be deemed a pushed goal.
- 4.5.3. The only exception to this is when a robot makes first contact with the ball at less than 15cm from the goal. This includes contact being made by the ball or the attacking robot with another robot or the goal post.
- 4.5.4. A penalty goal will be awarded if a ball deemed to be travelling into the goal strikes a defensive robot that has some part of it over the goal line and in the "in goal" area. Robots should be built in a manner that the cross bar prevents them from going behind the goal line.
- 4.5.5. After a goal is scored, a kickoff will occur. The non-scoring team will be awarded the ball.
- 4.5.6. "Own goals" will be treated as a goal to the opposition, even if the ball is "pushed" into the goal.

4.6. Lack of Progress

- 4.6.1. "Lack of Progress" occurs if the ball is stuck between multiple robots ("forcing" situation) for a reasonable amount of time and has no chance of being freed or if no robot has any chance of locating the ball in a reasonable amount of time.
- 4.6.2. The referee will call "Lack of Progress" immediately when a robot is using greater power to "force" the ball past the opposition. *If a referee is slow to remove the ball and a goal is scored as a direct result of a robot "forcing" the ball through, the goal will be disallowed and the ball placed on the nearest neutral zone.*
- 4.6.3. In the case of "Lack of Progress", the ball will be moved to the nearest neutral zone. If this occurs again, the ball will be moved to the centre of the field.
- 4.6.4. When "Lack of Progress" is called, any robots stuck on other robots will be freed using minimal movement by the referee or team captains at the request of the referee.

4.7. Damaged Robots

- 4.7.1. If a robot does not move and/or does not respond to the ball, it will be deemed damaged by the referee.
- 4.7.2. If a robot remains in the in goal area for longer than 20 seconds, or is stuck against walls or goals, and shows no indication of returning to the playing area, it will be deemed damaged by the referee.
- 4.7.3. The referee or players (with the referee's permission) may remove damaged robot(s) from the field.
- 4.7.4. A damaged robot must remain off the field for at least one minute.
- 4.7.5. A damaged robot must be repaired and may be returned with the referee's permission to the neutral zone that is closest to the position on the field from where the robot was removed and does not advantage that robot, e.g. facing the ball.
- 4.7.6. Goalies may be returned to the area in front of the goal.
- 4.7.7. Play will continue during removal, repair and replacement. Note that the referee may choose to interrupt play if robot damage occurred because of a collision with an opposition robot.
- 4.7.8. If a robot turns over on its own accord, it will be treated as a damaged robot and removed. If the robot is tipped over after a collision with another robot, it can be righted by the referee and continue playing.

4.8. Ball Out Of Play

- 4.8.1. A ball is considered out of play if it strikes the outer wall or leaves the playing field.
- 4.8.2. After a ball is considered out of play, it will be moved to the nearest neutral zone to the disadvantage of the team of that last touched it. I.e. the neutral zone in the direction that the opposition are kicking.

4.9. Interruption of Game Play

- 4.9.1. The situations listed in sections (4.6) - (4.8) may cause play to be interrupted, usually resulting in the movement of the ball to the nearest neutral zone while play is allowed to continue.
- 4.9.2. Play may also be stopped by the referee blowing a whistle (Referee's Time Out), but the game clock is not stopped, all at the discretion of the referee. All robots must be stopped immediately and returned to their position at the time the whistle was blown.
- 4.9.3. After a stoppage in play, play will resume on the referee's command and all robots are started simultaneously.
- 4.9.4. A referee may call "Referee's Time Out" for field repair, situations such as in (4.7.7) or (4.11.3) or if the tournament referee is called for rule clarification. The referee can elect to stop the match clock if the stoppage is lengthy.

4.10. Multiple Defence

- 4.10.1. "Multiple Defence" occurs if more than one robot from the defending side enters the penalty area and substantially affects the game.
- 4.10.2. For a "Multiple Defence", the robot having the least influence on play is moved to the centre of field. In the case where a goalie is involved, the other player will be moved.

4.11. Fouls

- 4.11.1. If a robot utilizes a device or an action which continuously attacks or charges a robot not in possession of the ball, the referee will call "Foul". The team captain must then

remove the robot from the playing field for at least one minute and correct the problem; play will continue (as in 4.7 “Damaged Robots”).

- 4.11.2. If the robot continues to foul, it will be permanently removed from the game, a yellow warning sticker will be placed on the robot/s and the referee will record the infringement on the score card.
- 4.11.3. If a robot is damaged by a foul, the referee will stop the game and stop the clock while repairs are made. (See Referee’s Time Out - Section 4.9.4)
- 4.11.4. If a robot is removed from two games for “fouling”, it will be disqualified from the tournament.

4.12. Free Kicks

- 4.12.1 There are no free kicks.

4.13. Penalty Kicks

- 4.13.1. There will be no penalty kicks throughout the match. However, if the match ends in a tie, each team will be given 5 penalty kicks to determine the winner of the match.

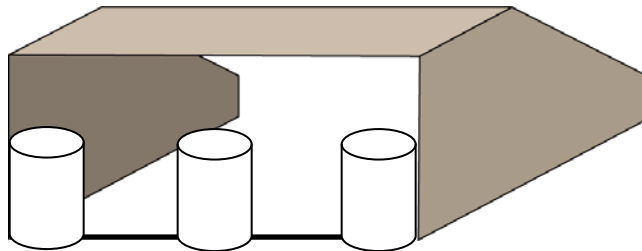

- 4.13.2 The ball will be placed in the middle of the field and only one robot is allowed to take the penalty kick. The team taking the penalty kick must place their robot in their penalty box.
- 4.13.3 3 drinks can (filled with water) will be placed on the goal line as a barrier; one in the middle and the other two next to each goal post.

4.14. Offside

- 4.14.1. There are no offside rules.

4.15. Humans

- 4.15.1. In general, movement of robots by humans is not acceptable.
- 4.15.2. Humans can only move robots at the instruction of the referee.
- 4.15.3. Before the start of each match, teams should designate one human who will act as "Captain", and be allowed to place, remove and replace robots during the game, based on the stated rules and as directed by the referee.
- 4.15.4. Other team members within the vicinity of the playing field are to remain at least one meter from the field while the ball is in play, unless otherwise directed by the referee.

5. Conflict Resolution

5.1. Referee

- 5.1.1. During game play, the referee's decisions are final. Any argument with a referee's decision will result in a Yellow Warning Card. If argument continues, the referee will give a Red Card resulting in immediate forfeit of the game.
- 5.1.2. If Team Captains are satisfied with the result of a game, they are to sign the score sheet at the conclusion of game play.

5.2. Rule Clarification

- 5.2.1. Rule clarification may be made by members of the NRC GEN II Football Advisory Council.
- 5.2.2. If a rule clarification is needed, the referee should stop the game immediately, call "Referee's Time Out" (See Referee's Time Out - Section 4.9.4) stop the clock and confirm the ruling before continuing with the game.

5.3. Special Circumstances

- 5.3.1. Specific modifications to the rules to allow for special circumstances, such as unforeseen problems and/or capabilities of a team's robots, may be agreed to at the time of the tournament, provided a majority of the contestants agree.

6. Inspection

6.1. Scrutineering

- 6.1.1. All robots will be examined by a panel of referees before the start of the tournament to ensure that the robots meet all constraints described in Section 3.
- 6.1.2. It is the responsibility of teams to have their robots inspected if their robots are not passed at scrutineering or have been modified at any time during the tournament.
- 6.1.3. Any violations of the inspection rules will prevent that robot competing until modifications are affected.
- 6.1.4. Modifications must be made within the time schedule of the tournament and teams must not delay game play while making modifications.
- 6.1.5. If a robot fails to meet all specifications (even with modification), the robot will be disqualified for that game (but not the tournament).

6.2. Students

- 6.2.1. Students will be asked to explain the operation of their robots in order to verify that the construction and the programming of the robot is their own work.
- 6.2.2. Students will be asked questions about their preparation efforts, and they will be requested to answer surveys and participate in videotaped interviews for research purposes.
- 6.2.3. Proof (photos, log books, poster, plans etc) must be supplied to show that robots are constructed and programmed by the students. The use of purpose built programs supplied with kits or at training sessions should not be used without major modification. Proof of a full understanding of the program must be shown.
- 6.2.5. It is expected that judges will conduct verification interviews at any time requested.
- 6.2.6. Any violations of the inspection rules will prevent that robot competing until modifications are affected.
- 6.2.7. Modifications must be made within the time schedule of the tournament and teams must not delay game play while making modifications.
- 6.2.8. If a robot fails to meet all specifications (even with modification), the robot will be disqualified for that game (but not the tournament).
- 6.2.9. If there is excessive mentor assistance or the work on the robots is not substantially original work by the students, then the team will be disqualified from the tournament.

7. Code of Conduct

7.1. Fair Play

- 7.1.1. Robots that cause deliberate interference and repeated damage to structurally sound robots during normal game play will be disqualified (See Section 4.11. (Fouls)).
- 7.1.2. Robots that cause damage to the field or the ball during normal game play will be disqualified (see Section 3.8.).
- 7.1.3. Humans that cause deliberate interference with any robots or damage to the field or the ball will be disqualified.
- 7.1.4. It is expected that the aim of all teams is to play a fair and clean game of Football. It is expected that all robots will be built with Rules 3.8 and 4.11 in mind. If robots are built to the upper limits of power and weight, they must anticipate the possibility of damaging other robots or the ball. Officially endorsed NRC balls have been tested for robustness and are not damaged in normal GEN II Football game play.

7.2. Behaviour

- 7.2.1. All movement and behaviour is to be of a subdued nature within the tournament venue.
- 7.2.2. Competitors are not to enter setup areas of other tournaments or other teams, unless expressly invited to do so by team members.
- 7.2.3. Participants who misbehave may be asked to leave the building and risk being disqualified from the tournament.

7.3. Mentors

- 7.3.1. Mentors (teachers, parents, chaperones and other adult team members) are not allowed in the student work area.
- 7.3.2. Mentors are not to repair robots or be involved in programming of student robots. Robots should not need to leave the student work area during the day's game play.

7.3.3. Mentor interference with robots or referee decisions will result in a yellow card warning in the first instance. If this reoccurs, a red card will be awarded and the mentor will be asked to leave the venue.